

EN General installation and operation manual for Romotop fireplace inserts

- valid in general for all types of fireplace inserts manufactured by Romotop spol. s.r.o.
The attached technical sheet lists detailed technical data for each type of fireplace insert.

Installation of fireplace inserts may only be done by reseller authorized by Romotop spol. s r. o. .

The fireplace inserts may only be operated in accordance with this manual!

No unauthorized changes may be performed on the fireplace inserts!

1. Introduction
2. Technical description
3. Safety regulations
 - 3.1 Safe distances
 - 3.1.1 Safe distance of fireplace inserts from flammable materials
 - 3.1.2 Safe distance of flue pipes from flammable materials and building constructions
 - 3.2 Floor protection
 - 3.3 Chimney fire prevention measures
4. Assembly regulations
 - 4.1 General
 - 4.2 Chimney connection
 - 4.3 Enclosure of fireplace inserts
5. Operation manual
 - 5.1 Fuel
 - 5.2 Starting the fireplace insert for the first time
 - 5.3 Kindling and firing
 - 5.4 Stoking fuel
 - 5.5 Operation during the transition period
 - 5.6 Ash removal
6. Cleaning and maintenance
 - 6.1 Cleaning the glass
 - 6.2 Cleaning the fireplace inserts / disassembly of chamotte
 - 6.3 Cleaning the chimney
7. Disposal of covers and the discarded product
8. Warranty

1. Introduction

Thank you for purchasing our fireplace insert and congratulations for becoming the owners of top-notch fireplace inserts by Romotop spol. s.r.o., one of the forefront European manufacturers of fireplace heaters.

Our fireplace inserts can function as additional heating to augment the atmosphere of your home or recreational building or as the main source of environmentally-friendly heating with high heat output, dust-free operation and perfect combustion. All fireplace heaters produced by our company are tested in accordance with ČSN EN 13 240/2002 or ČSN EN 13 229/2002.

Please read through the manual and technical sheet thoroughly. The user is obliged to get properly acquainted with proper installation and operation of this device with regards to its safe operation. Please keep the manual and technical sheet so that you can brush up all the information necessary for the correct operation of your fireplace insert before each heating season.

We only provide a warranty on our products if all the instructions listed in this operation manual are adhered to.

2. Technical description

Fireplace inserts are intended for building into stoves in various interiors (apartments, recreation buildings, restaurants). Romotop spol. s.r.o. fireplace inserts are manufactured from quality construction materials – cast metal, CORTEN steel and quality construction and fittings steel, with stressed parts made of HARDOX steel. The surface of steel constructions is protected by a refractory opaque paint. Refractory paints are not anti-corrosive. The combustion chamber of full-plate fireplace inserts is padded by removable chamotte desks, which are not connected by any paste material to prevent damage by heat dilatation. The combustion chamber can be firmly closed by doors with special heat-resistant glass. The glass not only increases the aesthetics of the flickering flames, but also facilitates pleasant heat radiation. The glass also prevents the sparks from the burning wood and smoke from entering the room. The floor of the combustion chamber is usually equipped with a removable cast-iron grate. Usually, a barrier, or alternatively a sheet metal or ceramic mould, is placed in front of the grate to prevent the fuel falling and sliding onto the doors (front window). Grate fireplaces include room for an ashpan under the grate. Some types allow custom-configuration of the flue pipe throat for top- or back-side exhaustion. Some types of fireplace inserts have a rotary exhaust flue pipe throat. The fireplace insert design may include a single coating or be supplemented with an external coat of zinc-coated sheet metal with outlets for connection to the heat system. Installation of a support fan is recommended for vertical heat pipes longer than **4m**.

Fireplace inserts equipped with a separate intake of primary and secondary combustion air include the appropriate control elements. The primary air is taken to the burning fuel (usually through the ashpan and grate) and is used for primary combustion. The secondary air supports combustion of residual combustible gases in the exhaust, increasing the output of the heater and significantly reduces the amount of pollutants escaping into the atmosphere. The secondary air is mostly taken to the area above the burning fuel. Its presence causes the cold air to roll around the inner side of the front glass. This process simultaneously prevents the blackening of the front glass. The secondary air also participates in the primary combustion process when the primary air intake is partially or completely sealed. Keep the primary air intake fully open at the beginning of the combustion process, when the chimney draft is still weak. After the chimney heats up, you can partially or even completely close the primary air intake, based on the target output of the fireplace insert. It is also possible to reduce the fueling or limit the chimney draft by attaching a smoke shutter (a manual shutter in the flue pipe limiting the air intake to at most **75%**) to reduce the output of the fireplace insert. This is recommended especially for chimney draft around and above **20Pa**. The secondary damper is intended to fully close the stove when it is not in operation. The fireplace and ashpan covers must always be closed except for starting operation, adding fuel and removing solid combustion remnants to prevent exhausts entering the room.

It is possible to install heat and accumulation exchangers behind certain fireplace inserts, increasing the efficiency of the whole stove and maximally utilizing fuel energy. Heat exchangers can be built into certain types of fireplace inserts, in which case the production of warm service water also utilizes the double external cover of the fireplace insert.

Some fireplace inserts are manufactured with a central air intake (CAI). This allows air to flow into the combustion chamber in the fireplace insert from the exterior, halls, technical rooms etc. Fireplace inserts with a CAI are not dependant on the amount of air in the heated area. Thus, they not only contribute to a pleasant atmosphere in your home, but also reduce energy expenses (since heated air already in the room is not consumed).

Fireplace inserts with a CAI are very convenient for stoves in low-energy houses. It is also possible to equip the heating system of some fireplace inserts with CAI with electronic combustion regulation to increase comfort. This can additionally increase the combustion process and stoking intervals, increase operation safety and prevent uneconomic heating and over-heating of fireplace inserts (the shutter of the central air intake is controlled by a control unit and servomotor in relation to the current combustion phase and output exhaust temperature).

Warning: The fireplace inserts are not manufactured to provide continual heating and are intended for periodic interrupted operation, mostly due to the need to empty the ashpan when the ash has cooled down.

3. Safety regulations

The fireplace inserts may be used in normal environments in accordance with ČSN 33 2000-1 ed.2/2009. In case of change of environment that could cause a temporary danger of fire or explosion (e.g. gluing linoleum, PVC, working with paints, etc), the fireplace insert must be put out of operation in time, i.e. before the occurrence of the dangerous situation. Furthermore, the fireplace inserts can be used only after the room is thoroughly aired, preferably by wind draft.

A supply of sufficient amount of combustion air and room ventilation air must be ensured when the fireplace stoves are in operation, especially with another heat device running simultaneously (approx. 8 to 15 m³ for burning 1 kg of fuel)! When doors and windows are tightly sealed, this might not be the case! This is solved by a CAI connected into a separate room. The regulation grate for combustion, ventilation and heating air must not be obstructed. When stoking fuel, always open the door very slowly. You will prevent smoke and ash from escaping into the room. The fireplace inserts require casual attendance and inspection.

Flammable fuels must not be used for stoking or heating! In addition, burning plastic material of any kind, wood materials with various chemical bonding agents (chipboards, etc) or unsorted domestic waste with remaining plastics is prohibited by law no. 201/20212.

Make sure to prevent children from handling the fireplace insert during heating. The fireplace insert may only be operated by an adult person!

During heating all handles and knobs must be operated using a pair of tongs, hook or by a hand protected by a glove (pot-holder) - there's a danger of burns! Objects made from flammable materials that could be set on fire must not be stored on the fireplace inserts during operation and while hot. Please pay special attention when handling the ashpan and when removing hot ash due to danger of burns! The hot ash must not get in contact with flammable objects - e.g. when throwing in communal waste containers.

When the fireplace insert is used only seasonally and with unfavorable draft or weather conditions, special attention must be paid when putting the stove into operation. When the fireplace stove is not in operation for a longer period of time, the flue ways must be checked for obstructions before further operation.

The appropriate safety regulations for fireplace insert operation and installation must be adhered to in accordance with ČSN 06 1008/1997, especially:

3.1 Safe distance:

3.1.1 Safe distance of fireplace inserts from flammable materials

When installing the fireplace insert in a place containing flammable materials belonging to class B, C and D, the required safe distance in accordance with ČSN 06 1008/1997 is 80cm from doors and 40cm in other directions (see Figure 1), for fireplace inserts with double coating this amounts to 20cm. When installing the insert in a place containing flammable materials belonging to class E or F, the distance must be doubled. Information on the degree of flammability of certain building materials is listed in ČSN EN 13 501-1+A1/2010 and ČSN 73 0810/2016. When the prescribed safe distance of the heater from the flammable materials cannot be kept, it is necessary to use a protective screen according to 4.4.1 ČSN 06 1008/1997.

Building materials sorted based on their reactivity with fire	
A1 or A2	granite, sandstone, concrete, bricks, ceramic tiles, special plasters ...
B	akumin, Heraklith, Lignos, Itaver ...
C	hardwood, plywood, Sirkolit, hardened paper, umakart ...
D	softwood, chipboards, Solodur, cork boards, rubber, flooring ...
E or F	fibreboards, polysterene, polyurethane ...

Distance from flammable materials. Table Technical sheet

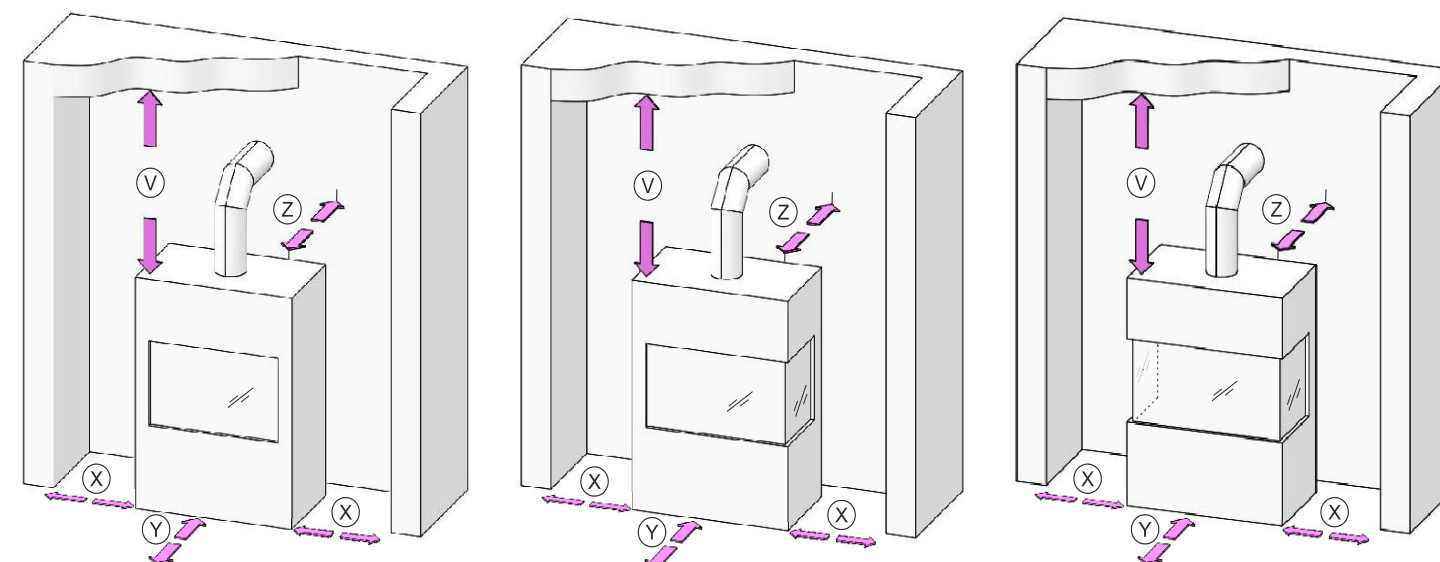

3.1.2 Safe distance of chimneys from flammable materials and building constructions

The safe distance from door case covers and similarly located building constructions from flammable materials and from pipeline installation including its insulation is at least 20cm. The safe distance from other flammable parts of the building construction at least 40cm (see fig.2) according to ČSN 06 1008/1997. This includes building materials belonging to classes B, C and D as defined in ČSN EN 13501-1+A1/2010 (see table no.1) The same applies for walls and especially ceilings with plaster on a flammable surface, e.g. crates, planks, etc.! When the prescribed safe distances cannot be kept, the danger of fire must be prevented through construction solutions, non-flammable applications, heat-resistant insulations or protection screens.

3.2 Floor protection

Unless the fireplace is installed on a 100% non-flammable floor, it is necessary to place it on a non-flammable insulation mat, e.g. metal plate (at least 2mm thick), ceramics, hardened glass, stone, in order to prevent the flammable floor to exceed a temperature of 50°C during operation in accordance with ČSN 73 4230/2014.

According to 5.1.3.3 of ČSN 06 1008/1997, the insulation mat must exceed the fireplace by at least

- 80cm in the vertical direction from the insert stoking door.
- 40cm in the horizontal direction from the insert stoking door.

Items made of flammable materials may not be placed on top of or at a less-than-safe distance from the fireplace insert.

3.3 Chimney fire prevention measures:

Ordinary operation, especially with humid fuel, leads to the settling of ash and tar in the chimney. Neglecting regular checking and cleaning of the chimney **in accordance with the government regulation no. 34/2016 Coll. from 22st January 2016** increases the danger of fire.

In case of ash or tar catching fire in the chimney, please follow this procedure:

- do not under any circumstances extinguish the fire with water as it would create an abnormal amount of steam and subsequently rip the chimney open
- if possible, the combustion chamber should be covered with dry sand, which will extinguish the fire
- close all intakes of air for combustion; if possible, cover the chimney. However, the smoke must not accumulate back in the house
- contact your nearest fire fighting brigade to assess the situation and the necessity to report it as a fire fighting emergency
- do not leave the house until the chimney is burned up; regularly check the chimney temperature and the course of combustion
- contact a chimney service before starting a new fire in the stove to assess the state of the chimney and also contact the manufacturer of the fireplace insert for inspection.

4. Assembly regulations

Warning: All local regulations, including regulations concerning national and European standards for this type of appliances, must be adhered to:

- ČSN 73 4230/2014 - Fireplaces with open and closable furnace
- ČSN EN 13229/2002+A1/2003+A2/2005 - Built-in heating appliances and open fire inserts for solid fuel
- ČSN EN 13240/2002+A2/2005 - Room heaters fired by solid fuel
- ČSN 73 4201/2016 ed.2 - Chimneys and connecting flue pipes - Design, construction and installation of heating appliances
- ČSN EN 1443/2004 - Chimneys – General requirements
- ČSN EN 13501-1+A1/2010 - Fire classification of construction products and building elements
- ČSN 06 1008/1997 - Fire protection of heating appliances
- Decree No. 268/2011 Coll. - Technical conditions of fire protection of buildings

4.1 General

The fireplace insert must be installed on the appropriate stand supplied by the manufacturer or on a brick pedestal on floors with an appropriate load capacity. In case of fireplace inserts with an enclosure, it is necessary to also consider the weight of the enclosure! If the existing arrangement does not meet this basic requirement, necessary steps must be taken (e.g. using a mat for distributing the load). Make sure that there is enough space for cleaning the fireplace insert, connecting flue pipes and the chimney unless the chimney can be cleaned from other place, e.g. a roof or through doors designed for this purpose.

4.2 Chimney connection

Before assembling the closed fireplace insert it is necessary to calculate that the chimney construction will be suitable for the installed fireplace insert nominal output as far as design, vent size and effective height are concerned.

A suitable chimney (minimum profile, chimney draft, tightness, etc.) is a basic condition for the proper functioning of the fireplace inserts. You should therefore contact a chimney sweeper before installing the

fireplace insert. Chimney values are included in the attached technical sheet. A smoke shutter or a draft regulator should be installed for chimneys with too strong a draft. Such a draft can cause problems during operation, e.g. intensive burning, high fuel consumption and can also lead to permanent damage of the fireplace insert.

The minimum effective height of the chimney for exhaust gas from the insert is **5m** (measured from the hoop to the chimney mouth). The chimney entry must be equipped with a chimney hoop. Consult the vent connection with the vent manufacturer. The vents must lead at least **5cm** below the lower ceiling. Connect the flue mouth with the chimney in the shortest possible way so that the flue length is at most **1/4** of the effective height of the chimney (i.e. **1.5m**). Connect the flue tube and the knee together with an overlap in such a way that the connections always agree with the exhaust gas flow, or abut using the connection rings. If the connecting piece passes through construction elements with flammable materials, it is necessary to use protective measures in accordance with **ČSN 06 1008/1997**. The norm states that the flue pipe needs to rise to the vents in the direction of exhaust flow with a degree of at least **3°**. The tightness and firmness of the joints is crucial. The chimney and stove connection must adhere to **ČSN 73 4201/2016 ed.2**. The casing of the chimney must not exceed a temperature of **52°C** during the highest operation temperature of the stove. The cross section of the flue pipe vents must not be larger than the cross section of the chimney vent and it must not narrow down in the direction of the chimney. If calculations show that the cross section of the flue pipe and chimney vent could be smaller than the cross section of the exhaust throat of the fireplace insert, the cross section of the flue pipes will be lowered immediately behind the exhaust throat of the fireplace insert, either gradually or at a discrete point. The flexible flue pipe from the materials in accordance with table **A.1.** may only be used in places where it may be checked in accordance with **7.2.1 ČSN 73 4201/2016 ed.2**, and unless the flue pipe leads through an open air its checkability must be ensured in accordance with **7.2.5 ČSN 73 4230/2014**. A vertical flue pipe may only be used in the cases listed in **8.3.4 and 8.3.5 ČSN 73 4230/2014**.

The fireplace insert may be connected to a shared vent with a gas appliance for multi-layer chimneys in accordance with **ČSN 73 4201/2016 ed.2**.

4.3 Enclosure of fireplace inserts

Special expertise is required for building the fireplace insert into the fireplace. Fireplace construction is adjusted by norm **ČSN 73 4230/2014**. **Installation of fireplace inserts may only be done by reseller authorized by Romotop spol. s r. o..**

When installing and installing a fireplace insert, follow these guidelines:

1. All security and construction regulations listed above must be followed.
2. After installing the whole fireplace, the inlet and outlet of conventional air through any construction parts must not be limited. The cross section of the inlet and outlet of convect air is listed in the technical sheet.
3. To augment the final appearance of the fireplace, the dimensions of the door frames exactly match the ceramic facing produced by Romotop spol. s.r.o.
4. The enclosure must be made of suitable, designated materials.
5. The warm conventional air outlet must be at least **30cm** below the ceiling (figure 2).
6. An inflammable ceiling construction must be present above the conventional warm air outlet. Its temperature must not exceed **50°C**. Thus, the lower ceiling must be insulated from the effects of heat coming from the fireplace by a barrier and at least one not fully closeable grated opening (figure 2) or a sufficient layer of heat insulation.
7. The same requirements also hold for the walls next to the fireplace and for the floor. A ventilated air space must remain between the heat insulation and the wall. It is recommended to glue aluminum sheets on the surface of walls.
8. The wall of the fireplace must not contain electric wiring and water or gas distribution pipes. The wall nor its surface may contain flammable materials or materials which may release harmful substances when heated.
9. Minimal free distances must be kept between the fireplace insert and the cover (see technical sheet) for the whole height and width of the fireplace insert, so that convect air can freely circulate and prevent the

overheating of the fireplace set.

10. Eventual air conditioning piping must be located at least **40 cm** from flammable building constructions, or it must be documented that the heat from the piping cannot cause the construction to catch on fire. Convect air can reach temperatures of up to **300°C** near the insert!

11. **Do not forget** that fireplace inserts also spread heat in the direction of the floor. The floor under the fireplace and at a distance of at least 80cm in front of the furnace and 40cm to the sides of the furnace must be made of an inflammable material. The distance is measured from the closer edge of the furnace. The surface for the fireplace must have an appropriate load capacity.

12. **Do not forget** that when considering the use of wooden decorative ledges, these must be made of quality wood with a humidity of at most 15% and that convect cooling air must flow around it with a gap of at least **1cm** or they must be heat-insulated from the fireplace, so that their surface temperature does not exceed **52°C**.

13. When distributing hot air via natural air circulation, it is recommended to use horizontal pipes at most 4m long. When distributing hot air via forced air circulation, the length of pipes is not limited.

14. The pipes for distributing hot air must be tight and made of a material resistant to operating temperatures. We recommend insulating them at the whole length, especially where they traverse walls, ceilings or around flammable materials.

15. Hot air outlets must not be located at areas with materials susceptible to structural changes caused by temperature fluctuations (e.g. polyester lining, certain types of wallpapers etc.)

16. No construction changes or adjustments may be performed on the fireplace insert!!!

All local regulations, including regulations concerning national and European standards. Have a specialized project elaborated before construction.

The project documentation must be elaborated in a scale of **1:10** or **1:20**. Before the fireplace enters operation, it must be inspected by a chimney sweeper and the exhaust path must be inspected in accordance with **Chapter 9 of ČSN 73 4201/2016 ed.2**. Inspection of the flue pipe connection to the insert and chimney vents should be performed before closing the exhaust path to the hot air chamber. The result of the inspection shall be recorded in the exhaust gas inspection report including the technical report according to Decree No. 34/2016 Coll. **Please keep the Revision Report and the Technical Report carefully!**

Vertical cross section of single-coating fireplace with closable furnace

- 01 – chimney vent
- 02 – wall
- 03 – insulation area above the chamber
- 04 – hot air chamber ceiling
- 05 – ventilated air gap
- 06 – heat insulating layer
- 07 – hot air chamber area
- 08 – fireplace insert flue pipe
- 09 – fireplace insert smoke chamber
- 10 – closed fireplace furnace
- 11 – air intake from other rooms (or CAI)
- 12 – ventilation of ceiling insulation areas
- 13 – hot air outlet from the chamber
- 14 – heat insulating layer
- 15 - wall of hot air chamber
- 16 – fireplace ledge
- 17 – fireplace ledge protection
- 18 – air intake for hot air chamber
- 19 – air intake from the room to under the fireplace insert
- 20 – inflammable floor (pad) in front of the fireplace
- 21 – CAI throat

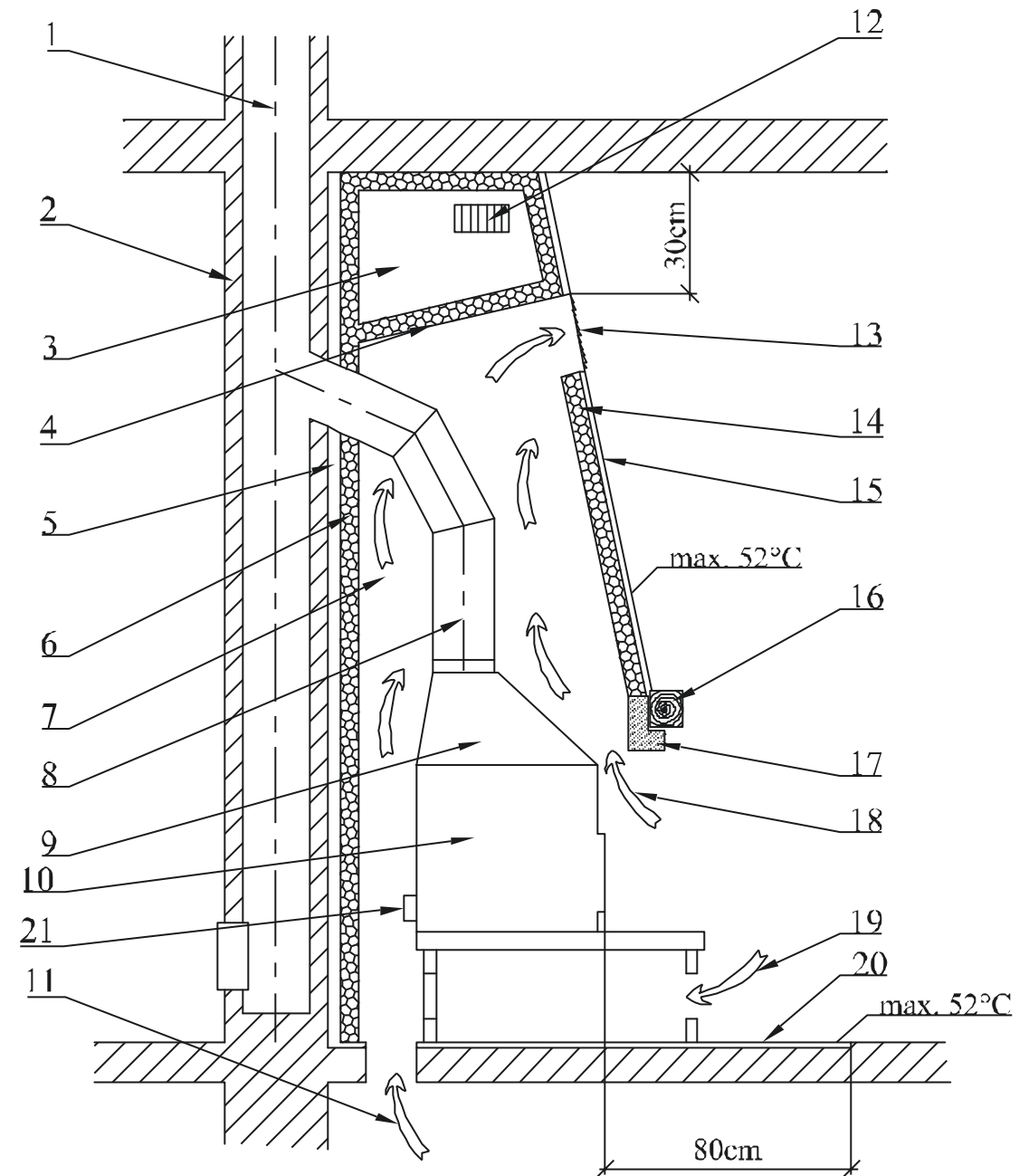

Figure 2

A chart of the fireplace set holds in general also for double-coating fireplace inserts and fireplace inserts with a heat-accumulating and warm water exchanger.

5. Operation manual

5.1 Fuel

It is only allowed to burn wood in fireplace inserts in accordance with law **No. 201/2012 Coll.**. To reach the nominal parameters of the heater, we recommend using dry logs with a diameter of **5-8 cm** and length of **20-30 cm** and with a humidity below **20%** (ideally **10%**). Oven wood and chopped pieces of wood should be used only when starting the fire. Recommended humidity can be obtained by storing the chopped logs for at least two years in a ventilated shelter.

The fireplace insert should be heated to a nominal output stated in the technical sheet, i.e. the burning of a given amount of allowed fuel per **1 hour**. Long-term excessive output could damage the fireplace stove.

Never use flammable fluids, coke, coal or any of the following types of waste as fuel: chipboards, plastics, plastic bags, soaked wood or wood-shavings, saw-dust or pellets!

!!!Burning of the abovementioned material not only highly pollutes our environment but also damages the fireplace insert and the chimney!!!

5.2 Starting the fireplace insert for the first time

Before the first use all remaining stickers must be removed, all accessories must be taken out of the ashpan or fireplace and the same applies for the transport safety pins. **All plastic cover plugs on threaded connections are not functional, they are only used for transport.** Check that bulk shutters for directing the draft, chamotte tiles and the barrier are set correctly (as they might have slipped from their correct positions during transport or installation). Repair any defects you might find in setting, otherwise the proper functioning of the heater is endangered. After setting the fireplace insert, connecting it to the chimney and, if need be, connecting the exchanger to the warm-water set and filling it with a heat-carrying medium, start heating slowly and continue for at least one hour. Leave the stoves and ashpan doors open (**approx 1-2mm**) before and during the first heating in order to prevent the sealing material to mix with the paint. The fireplace insert surface is covered with heat-resistant paint. During the first heating, after becoming temporarily soft, the paint will eventually become hardened. During the soft phase the paint surface is more vulnerable to being damaged by a hand or other object. During the first heating the fireplace insert should be “heated up” with a small flame, burning only a small amount of fuel with a lower temperature. All materials must get used to the heat load. You will prevent cracks in chamotte bricks, damage of the paint or deformation of the insert materials by a careful first heating. Hardening of the paint on the fireplace insert might be accompanied by a temporary smell, which will disappear after a while.

Make sure the room is properly aired when burning the paint. Furthermore, ensure that no small animals or birds are present in the room containing paint exhausts. We also recommend turning off aquariums air intakes during the first heating.

In general, the heating up and cooling of the fireplace insert is accompanied by a specific sound; this is intended.

After the fireplace insert and eventually the exchanger cools down, it is possible to begin assembling the outer coating of the insert.

5.3 Kindling and firing

1. Fireplace inserts with grate - first put crumpled paper into the chamber and then lay chopped wood on it. You can also use the solid fire-lighter **PE-PO** to start the fire. After starting fire, let it burn freely with all air regulation elements open. **It is forbidden to use flammable liquid (oil, petroleum, etc.) for starting fire!** After the fire begins to burn and the draft is strong enough, bigger logs might be added without the danger of smoke. Continue stoking the amount of fuel determined based on the nominal output of the fireplace insert.

2. Fireplace inserts without grate - only secondary air is used for burning; therefore wood logs need to be stoked first, then chopped wood and finally small cuttings and paper. After starting fire, let it burn freely with all air regulation elements open. **It is forbidden to use flammable liquid (oil, petroleum, etc.) for starting fire!** After the fire begins to burn and the draft is strong enough, bigger logs might be added without the danger of smoke. Continue stoking the maximum amount of fuel determined based on the nominal output of the fireplace insert.

Fuel consumption is always stated in the technical sheet. Burning intensity is regulated by air intake controls or, if a smoke shutter is installed, by limiting the draft in the chimney. Larger amount of fuel or a strong draft

and air take might cause overheating and damage of the fireplace insert. Too weak draft leads to glass blackening or to a smoke escaping into the room when opening the door and stoking fuel.

Warning: Fireplace doors must always be closed, with the exception of the first heating, stoking fuel and removing ash. When the fireplace insert is not in operation for a longer period of time, it is necessary to check that the flue pipes, chimney and combustion chamber are clear.

5.4 Stoking fuel

In order to prevent smoke escaping into the room when stoking fuel, please follow the following procedure: Approximately 5 or 10 seconds before opening the fireplace doors open the air intake regulators and then only slightly open the stoking doors, wait for few seconds for the exhaust gas to get sucked into the chimney and only then fully open the door. When opening the stoking door, a special attention must be paid to the danger of hot fire-brands falling out. After stoking fuel, close the door again. After the fuel starts burning (with clear fire), return the regulator back to its original position. The amount of stoked fuel should correspond to an hourly consumption value for the concrete fireplace insert (see the technical sheet). Overheating can permanently damage the fireplace insert construction.

Warning: To prevent exhaust gas escaping into the room during stoking add fuel after its burning down on the glowing base.

5.5 Operation during the transition period

The chimney draft (sucking exhaust gas from the fireplace insert) might be weaker during the transition period, i.e. when the outside temperature is higher than **15°C**, during rainy and humid days or during gusty winds. During this period the fireplace insert should be operated with the minimum possible fuel so that the fire, as well as the chimney draft could be improved by opening the air intakes.

Tip: During this period a so-called atmospheric plug can be created in the chimney mouth due to the draft conditions. The plug can cause smoke escaping into the room when lighting fuel. We recommend letting a piece of paper burn down preferably in the upper part of the combustion chamber before lighting the kindling. This seemingly negligible smoke is enough to break through the atmospheric plug. Afterwards you can freely light paper (or solid fire-lighter PE-PO) and be sure that even a humid chimney is clear.

In this period it is also possible to use the same lighting method as for the fireplace inserts without grate (with no ashpan).

5.6 Ash removal

Make sure that the ashpan is cleaned when being half full in order to prevent the ash reaching too close to the grate and thus damaging it. At the same time the ash would block the intake of air required for burning. Removing ash from the ashpan should be carried out when the fireplace stove is cold and preferably ready for the next heating. A vacuum cleaner designed for cleaning ash with a filter for small filth can be also used for cleaning the cold ashpans or heater without ashpans. Ash from burnt wood can be used for composts or fertilizing. Store the ash in closed non-flammable containers.

Warning: Make sure that the ash does not contain any glowing remains of wood that could cause fire in the waste container.

Warning: For some fireplace insert types the ashpan is located in a basin under the grate and cannot be removed from the side. The ashpan can be removed only when the heater is cold and not in operation. The ashpan is accessible after lifting the grate.

Be careful when removing hot ash!

6. Cleaning and maintenance

Your fireplace insert is a high-quality product and no significant defects will appear during normal operation. Fireplace insert and flue system need to be checked and cleaned regularly and thoroughly before and after the heating season.

For cleaning and maintenance work you always have to make sure that the stove is not warm!

The surface of the fireplace stove is protected by flame-retardant coating. The flame-retardant coating is not anticorrosive. Avoid direct contact with water, other cleaning agents, abrasives or solvents.

Clean the surfaces of the fireplace stove with a soft, dry cloth!

6.1 Cleaning the glass

The cleanliness of the window is influenced not only by the using of suitable fuel, providing sufficient air intake and chimney draft but also by the method of operating the fireplace insert. In this respect we recommend stoking only one layer of fuel and distributing the fuel as evenly as possible and as far from the glass as possible. If the glass becomes dirty, try increasing the burning intensity by opening the air intake and the glass will clean itself.

Sooty windows can be cleaned in cold state using newspapers or wet cloth dipped in wood ash. Usually also liquid cleaning agents are used for cleaning the stove window. But these may in some cases, depending on the composition of the cleaning agent and its interaction with combustion residues (ash particles, etc.), harm the gaskets and/or the glass-ceramics and/or the decoration colour of the fireplace viewing panel.

The producer is not responsible for damages, which are caused by attack in using of chemical agents.

6.2 Cleaning the fireplace inserts / disassembly of chamotte

All sediments in flue pipes and combustion space must be removed during cleaning. Repair, ideally by removing, all fallen-off parts of the chamotte lining. The integrity of the chamotte lining must be monitored also during the heating season. Spaces between individual chamotte fittings serve as a heat dilatation preventing cracking of the fittings and must not be filled by filling material as was usual with older types of solid fuel heaters. **Cracked chamotte fittings are still functional until they fall out!** Bulk shutter for directing the draft, if used, should be removed during cleaning (this enables easier access to the space above them). The fireplace insert cleaning (with the exception of glass) should be done without water cleaner, i.e. using only vacuum cleaner or steel brushes. Any modifications of the fireplace insert are unacceptable. Use only spare parts approved by the manufacturer. Disassembly of chamotte (see the Chamotte chamber). From time to time the friction areas of the door hinge and the closing mechanism should be oiled using carbonic fat or grease designed for high temperatures. Close the fireplace insert with corresponding slide valves when not in operation.

6.3 Cleaning the chimney

Each user of a solid fuel heater is obliged to ensure regular checkups and cleaning of the chimney **in accordance with the government regulation no. 34/2016 Coll. from 22st January 2016.**

7. Disposal of covers and the discarded product

Packaging and the discarded product should be liquidated in accordance with law no. 125/1997 Coll. and

related regulations.

Packaging:

- a) wooden parts can be used for heating
- b) plastic package is to be placed into a container for sorted waste
- c) screws and handles are to be taken to a waste collection station
- d) bag with the separator of air humidity is to be placed to separated waste

Discarded product:

- a) dismantled glass is to be placed into a container for sorted waste
- b) sealing and chamotte boards are to be placed into communal waste
- c) metal parts are to be taken to a waste collection station

8. Warranty

Remember to read the attached guarantee certificate before you put your stove in operation. It contains information about obligations that must be met for possible guarantee claims to be recognized.

The guarantee does not cover damage caused by incorrect operation.