

Arlet



TECHNICAL DATA

HRP. Heat-resistant Paint	Yes
Ral	Op
Dual combustion	Yes
Double Hood	Yes
Detachable deflector	Yes
Ventilated back	No
Rotating system	No
Combustion	L-G-B
Wall mount bracket	No
Flue pipe to the ceiling	No
Spark arrestor	No
Commercial pipe connection diameter	H 180
Commercial pipe must be purchased separately	-
Net weight	115 kg
Gross weight	135 kg
Packaging	1000 x 1000 x 1700 mm

Performance	73%
Power	14,4 Kw

Model: Central
Enclosure: High

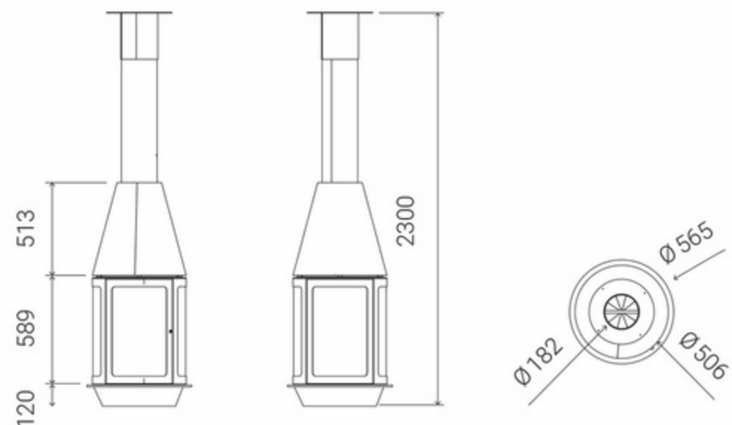

TRAFORART