

Hera



TECHNICAL DATA

| | |
|--|-----------------------|
| HRP. Heat-resistant Paint | Yes |
| Ral | No |
| Dual combustión | No |
| Double Hood | No |
| Detachable deflector | No |
| Ventilated back | No |
| Rotating system | Op |
| Combustion | L-G-B |
| Wall mount bracket | No |
| Flue pipe to the ceiling | No |
| Spark arrestor | Si |
| Commercial pipe connection diameter | H 250 |
| Commercial pipe must be purchased separately | - |
| Net weight | 110 kg |
| Gross weight | 130 kg |
| Packaging | 1000 x 1000 x 1700 mm |
| Performance | 36% |
| Power | 6 Kw |

Model: Central

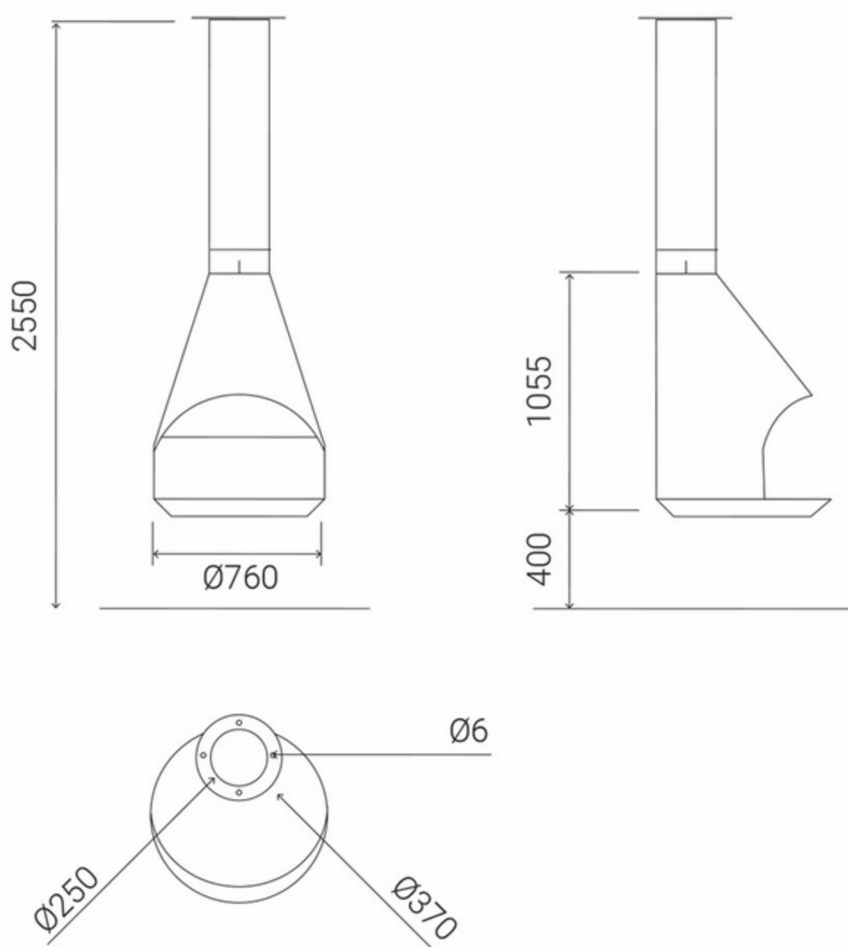

TRAFORART